

INTERNAL ADJUSTABLE ROTATING BROACH TOOL

This tool is used to produce hexagonal, square, and other non-round shapes on conventional lathes, mills, and screw machines without the need for a secondary operation. Due to the spindle offset, the turret forces needed to produce a part are minimized. The tool holder spindle is mounted in bearings allowing it to rotate or stop independent of the body without requiring auxiliary driving attachments.

Can be used on B&S, Davenport, and multi-spindle screw machines, as well as turret lathes and CNC machines.

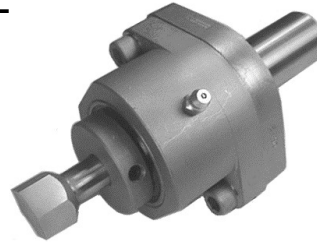

Also available with
CAT, VDI, CAPTO C6, HSK &
Morse Taper Shanks

Catalog Number	A	B	C	D	E	F	G
ORB00/0.625	5/8"	1-1/2"	1-7/8"			8MM	9/16"
ORB00/0.750	3/4"	2"	1-29/32"			Use	
ORB00/16MM	16MM	1-1/2"	1-7/8"	1-1/2"	2-7/16"	Broach	
ORB00/20MM	20MM					Series	
ORB00/22MM	22MM					--00	

ORB2/0.750	3/4"	2"	2-9/16"	2-3/8"	3-5/16"	1/2" Use Broach Series --2	3/4"
ORB2/1.000	1"						
ORB2/1.250	1-1/4"	3"					
ORB2/1.500	1-1/2"						
ORB2/20MM	20MM	2"					
ORB2/22MM	22MM						
ORB2/25MM	25MM						
ORB2/32MM	32MM	3"					

ORBHD/1.000	1"	3"	4-15/32"	3-1/2"	5-1/4"	3/4" Use Broach Series --HD	1-1/4"
ORBHD/1.250	1-1/4"						
ORBHD/1.500	1-1/2"						
ORBHD/1.750	1-3/4"						
ORBHD/32MM	32MM						
ORBHD/40MM	40MM						

Standard from stock H.S.S. broaches shown starting on page 12.
Broach gages available - see page 16.

Parts List			
Part Description	ORB00/... Cat. No.	ORB2/... Cat. No.	ORBHD/... Cat. No.
1. Shank	CALL	CALL	CALL
2. Body	ORB00-2N	ORB2-2N	ORBHD-2
3. Spindle	ORB00-3N	ORB2-3N	ORBHD-3
4. Radial Bearing	ORB00-4N	ORB2-4N	ORBHD-4N
5. Set Screw	ORB00-5	ORB2-5	FARH2-10
7. Clamp Screw & Washer	ORB00-7	ORB2-7	ORBHD-7
14. Angular Bearing	ORB00-14N	ORB2-14N	ORBHD-14
15. Seal	ORB00-15	----	----
18. Grease Fitting	ORB00-18	ORB00-18	ORB00-18
19. Spindle Nut	ORB00-19	ORB2-19	ORBHD-19
20. Spindle Washer	ORB00-20	ORB2-10	ORBHD-20

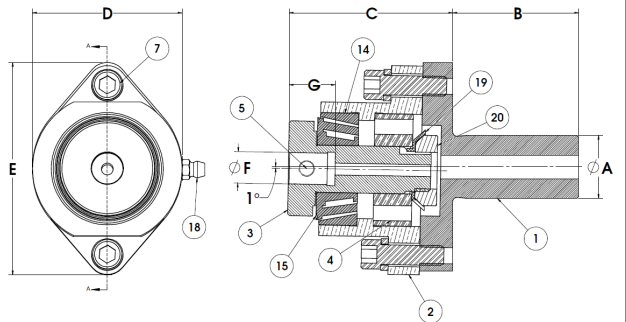

COLLET CHUCK STYLE ADJUSTABLE BROACH TOOL HOLDERS

More versatile, just change the collet to accept any shank diameter broaching tool within the collet range. For example, you can purchase three size collets, 0.315 (8mm), 0.472 (12mm), and 0.500 for the ER20 broach tool holder. This will allow you to use one holder for all common broach shank sizes. Built in stop screw allows you to adjust for different length broaches or to compensate for lengths on re-sharpened broaches. Eliminates necessity of centering cutting tool to "spindle" of broaching holder. No screws to knock cutting tool off center.



Standard from stock HSS broaches shown starting on page 12.
Broach gages available - see page 16.

Use only exact size **High Precision** DIN6499 ER collets.



**HIGH PRECISION
REPLACEMENT COLLETS
(Common Broach Shank Sizes)**

CAT. NO.	I.D.
ER16-8HP	8mm / .315
ER20-8HP	8mm / .315
ER20-12HP	12mm / .472
ER20-1/2HP	.500

FULL RANGE OF HIGH PRECISION
COLLETS AVAILABLE

Catalog Number	A	B	C	D	E	Nut Dia	Collet I.D. (Standard)	Broach Series #
ORB00-ER16M/0.625	5/8"	1-1/2"	2-7/16"	1-1/2"	2-7/16"	22MM	8MM	--00
*ORB00-ER16M/0.750	3/4"	2"	2-1/2"					
ORB2-ER20H/0.750	3/4"	2"	3-1/2"	2-3/8"	3-5/16"	1.348	1/2"	--2
ORB2-ER20H/1.000	1"							
ORB2-ER20H/1.250	1-1/4"							
ORB2-ER20H/1.500	1-1/2"	3"						

NOTE: COLLET NUT, COLLET WRENCH, SPINDLE WRENCH AND STANDARD HIGH PRECISION COLLET INCLUDED.
PRECISION COLLET INCLUDED WITH EACH CAT. NO.

ALSO AVAILABLE WITH METRIC SHANKS

*Limited Davenport applications due to 47/64" longer projection than standard broach holder ORB00/0.750 shown above.