

FLOATING (ADJUSTABLE) ER COLLET CHUCKS QUICK CHANGE OR STANDARD

- CAN COMPENSATE FOR UP TO .045" OF MACHINE MIS-ALIGNMENT.
- USES STANDARD ER COLLETS
- CAN BE ORDERED AS A STANDARD COMPLETE COLLET CHUCK **OR** WITHOUT THE COLLET NUT FOR USE WITH THE QUICK CHANGE ER SYSTEM.

SEE PAGE 121 FOR CORRESPONDING QUICK CHANGE HEAD ASSEMBLIES
SEE PAGES 156-160 FOR COLLETS

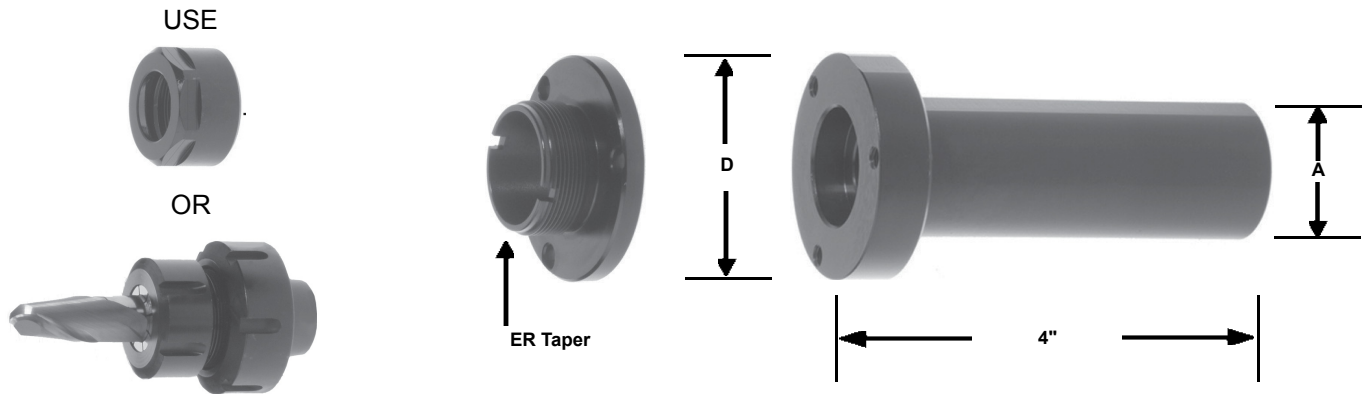

FLOATING (ADJUSTABLE) ER QUICK CHANGE COLLET CHUCKS

"A" SHANK DIA	"D"	COLLET SERIES	COLLET RANGE	CAT# FOR COMPLETE COLLET CHUCK W/ COLLET NUT	CAT# FOR QC SYS COLLET CHUCK MINUS COLLET NUT	FOR USE WITH HEAD ASSY SEE PAGE
5/8"	1-1/2"	ER16	1/16-13/32	SS062AFER16	SS062AFER16P	ER11S
3/4"	1-1/2"	ER16	1/16-13/32	SS075AFER16	SS075AFER16P	ER11S
3/4"	2"	ER20	1/16-1/2	SS075AFER20	SS075AFER20P	ER16S
3/4"	2"	ER25	1/16-5/8	SS075AFER25	SS075AFER25P	ER20S
1"	1-1/2"	ER16	1/16-13/32	SS100AFER16	SS100AFER16P	ER11S
1"	2"	ER20	1/16-1/2	SS100AFER20	SS100AFER20P	ER16S
1"	2"	ER25	1/16- 5/8	SS100AFER25	SS100AFER25P	ER20S
1-1/4"	2"	ER20	1/16-1/2	SS125AFER20	SS125AFER20P	ER16S
1-1/4"	2"	ER25	1/16-5/8	SS125AFER25	SS125AFER25P	ER20S
1-1/4"	2-1/2"	ER32	3/32-3/4	SS125AFER32	SS125AFER32P	ER25S
1-1/4"	2-1/2"	ER40	1/8-1"	SS125AFER40	SS125AFER40P	ER32S
1-1/2"	2"	ER20	1/16-1/2	SS150AFER20	SS150AFER20P	ER16S
1-1/2"	2"	ER25	1/16-5/8	SS150AFER25	SS150AFER25P	ER20S
1-1/2"	2-1/2"	ER32	3/32-3/4	SS150AFER32	SS150AFER32P	ER25S
1-1/2"	2-1/2"	ER40	1/8-1"	SS150AFER40	SS150AFER40P	ER32S
22MM	1-1/2"	ER16	1/16-13/32	SS22AFER16	SS22AFER16P	ER11S
22MM	2"	ER20	1/16-1/2	SS22AFER20	SS22AFER20P	ER16S
22MM	2"	ER25	1/16-5/8	SS22AFER25	SS22AFER25P	ER20S
32MM	2"	ER20	1/16-1/2	SS32AFER20	SS32AFER20P	ER16S
32MM	2"	ER25	1/16-5/8	SS32AFER25	SS32AFER25P	ER20S