

SOMMA DRILL SPEEDER

For use on New Britains, Acmes, Wickmans, Hydromats and other Multi Spindle Machines

Cat. No. DSPD

- 2" Diameter Quill
- 200 Double Angle Collet, 0-3/8" capacity
- 5,000 RPM
- 27 IN-LB of Torque
- Forward and Reverse
- Speed or Torque readout
- All electronics are in one box with a 3 wire hook up
- At speed or current limit output

For drilling small holes as well as cross hole drilling and milling.

SEE PAGE 162 FOR COLLETS



SOMMA AIR SPEEDER

PURPOSE:
ELIMINATE NEED FOR SECONDARY OPERATIONS. USE THIS TOOL TO DRILL, MILL, SLOT.
EASILY MOUNTS TO A CROSS SLIDE OR A 2" TOOL HOLDER.
FOR USE ON NEW BRITAINS, ACMES, WICKMANS, HYDROMATS AND OTHER MULTI SPINDLE MACHINES.

FEATURES:

- 2" DIAMETER QUILL
- 200 DA COLLET 0-3/8" CAPACITY
- 2,000, 3,300, 4,500 6,000 RPM
- 1/3 HP
- 15" OAL
- SIMPLE HOOK-UP, SUPPLY AIR AND DRIP LUBE.

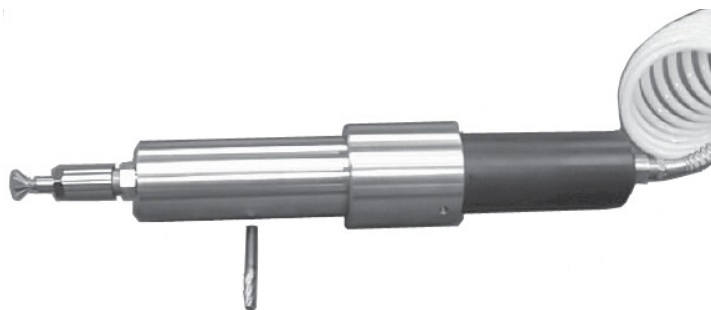
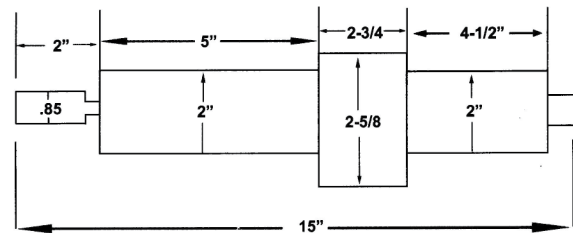

RPM	CAT. NO.
2000	DAPD-2000
3300	DAPD-3300
4500	DAPD-4500
6000	DAPD-6000

SEE PAGE 162 FOR COLLETS