

ER RIGID TAPPING COLLETS

HAND TAP SIZE	TAP SHANK DIA.	ER40 CAT. NO.	ER32 CAT. NO.	ER25 CAT. NO.	ER20 CAT. NO.	ER16 CAT. NO.	ER11 CAT. NO.
#0 - 6	.141	ER40-0141TH	ER32-0141TH	ER25-0141TH	ER20-0141TH	ER16-0141TH	ER11-0141TH
#8	.168	ER40-0168TH	ER32-0168TH	ER25-0168TH	ER20-0168TH	ER16-0168TH	ER11-0168TH
#10	.194	ER40-0194TH	ER32-0194TH	ER25-0194TH	ER20-0194TH	ER16-0194TH	ER11-0194TH
#12	.220	ER40-0220TH	ER32-0220TH	ER25-0220TH	ER20-0220TH	ER16-0220TH	ER11-0220TH
1/4	.255	ER40-0255TH	ER32-0255TH	ER25-0255TH	ER20-0255TH	ER16-0255TH	ER11-0255TH
5/16	.318	ER40-0318TH	ER32-0318TH	ER25-0318TH	ER20-0318TH	ER16-0318TH	
3/8	.381	ER40-0381TH	ER32-0381TH	ER25-0381TH	ER20-0381TH	ER16-0381TH	
7/16	.323	ER40-0323TH	ER32-0323TH	ER25-0323TH	ER20-0323TH		
1/2	.367	ER40-0367TH	ER32-0367TH	ER25-0367TH	ER20-0367TH		
9/16	.429	ER40-0429TH	ER32-0429TH	ER25-0429TH			
5/8	.480	ER40-0480TH	ER32-0480TH	ER25-0480TH			
11/16	.542	ER40-0542TH	ER32-0542TH				
3/4	.590	ER40-0590TH	ER32-0590TH				
13/16	.652	ER40-0652TH	ER32-0652TH				
7/8	.697	ER40-0697TH					
15/16	.760	ER40-0760TH					
1	.800	ER40-0800TH					
PIPE TAP SIZE							
1/8P (SS)	.313	ER40-0313PT	ER32-0313PT	ER25-0313PT			
1/8P (LS)	.437	ER40-0437PT	ER32-0437PT	ER25-0437PT			
1/4P	.562	ER40-0562PT	ER32-0562PT				
3/8P	.700	ER40-0700PT					
1/2P	.687	ER40-0687PT					



ER Rigid Tapping Collets with Square Drive

For synchronous tapping operations using any ER collet chuck. Collet bore is exact tool diameter, with square drive, for accuracy and rigidity. Available sealed for coolant-through applications, as well as in DIN and JIS standard metric sizes.

ER TAPPING COLLETS W/ AXIAL COMPENSATION

HAND TAP SIZE	TAP SHANK DIA.	ER40 CAT. NO.	ER32 CAT. NO.	ER25 CAT. NO.	ER20 CAT. NO.	ER16 CAT. NO.
#0 - 6	.141	ER40AF-0141TH	ER32AF-0141TH	ER25AF-0141TH	ER20AF-0141TH	ER16AF-0141TH
#8	.168	ER40AF-0168TH	ER32AF-0168TH	ER25AF-0168TH	ER20AF-0168TH	ER16AF-0168TH
#10	.194	ER40AF-0194TH	ER32AF-0194TH	ER25AF-0194TH	ER20AF-0194TH	ER16AF-0194TH
#12	.220	ER40AF-0220TH	ER32AF-0220TH	ER25AF-0220TH	ER20AF-0220TH	
1/4	.255	ER40AF-0255TH	ER32AF-0255TH	ER25AF-0255TH	ER20AF-0255TH	
5/16	.318	ER40AF-0318TH	ER32AF-0318TH	ER25AF-0318TH		
3/8	.381	ER40AF-0381TH	ER32AF-0381TH	ER25AF-0381TH		
7/16	.323	ER40AF-0323TH	ER32AF-0323TH	ER25AF-0323TH		
1/2	.367	ER40AF-0367TH	ER32AF-0367TH	ER25AF-0367TH		
9/16	.429	ER40AF-0429TH	ER32AF-0429TH			
5/8	.480	ER40AF-0480TH				
11/16	.542	ER40AF-0542TH				
PIPE TAP SIZE						
1/8P (LS)	.437	ER40AF-0437PT	ER32AF-0437PT			
1/4P	.562	ER40AF-0562PT				



ER Quick-Change Tapping Collets with Axial Compensation

For use with any ER collet chuck, these tapping collets help prevent tap breakage on machines requiring axial compensation. Friction-free ball-bearing drive. Metric sizes available upon request.

UNIVERSAL® DOUBLE TAPER COLLETS

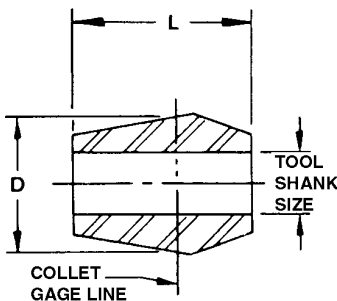

THE FOLLOWING COLLET CHUCKS ARE AVAILABLE FOR THESE COLLETS:

- STRAIGHT SHANK
- MORSE TAPER SHANK
- JACOBS INTERNAL TAPER
- BRIDGEPORT R8 SHANK
- #9 B&S TAPER SHANK

CALL FOR PRICE AND AVAILABILITY.

How to Order:

- Order by part number listed and tool shank size.
- Available in all letter, number & fractional sizes within range.
- Other sizes available to special order.

COLLET RANGE	TYPE	COLLET PART NO.	D	L
1/16 to 1/4	OW	*55021	.39	.50
1/8 to 3/8	WW	*55060	.59	.75
1/8 to 1/2	Y	*55097	.80	1.06
1/4 to 3/4	Z	*55132	1.12	1.50
3/8 to 1"	ZZ	*55165	1.56	2.00
3/4 to 1-1/2	XZ	*55194	2.20	2.50