

### ACME CUT-OFF TOOLHOLDERS

Patent No. D307859

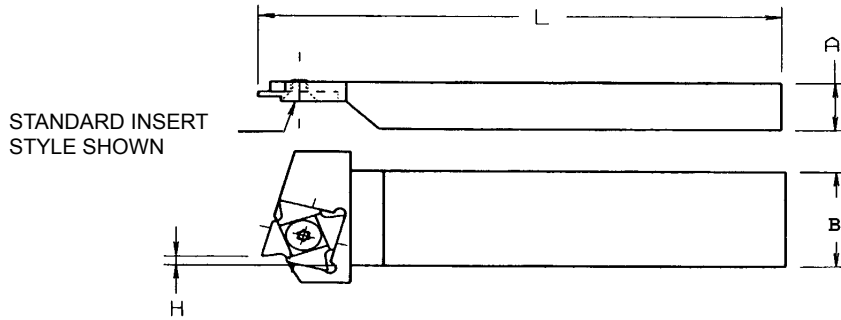

MACHINE SIZE	A	B	H	L	CAT# FOR TOOL HOLDER W/ POCKET FOR 3/4" SQ STANDARD INSERT	CAT# FOR TOOL HOLDER W/ POCKET FOR 1" SQ STANDARD INSERT
7/16" R/A	1.215	0.988	0.251	6.00"	7/16AC-CIN	7/16AC-CIN-EX
9/16" R/A	0.595	1.188	0.251	5.00"	9/16AC-CIN	9/16AC-CIN-EX
1-1/4" R/A	0.845	1.781	0.453	5.00"	1-1/4AC-CIN	1-1/4AC-CIN-EX
1-5/8" R/A	1.235	1.875	0.485	6.00"	1-5/8AC-CIN	1-5/8AC-CIN-EX
2" R/A	1.235	2.250	0.407	6.00"	2AC-CIN	2AC-CIN-EX
3" R/A	1.484	2.500	0.219	6.00"	3AC-CIN	3AC-CIN-EX

INSERT SIZE	INSERT SCREW#	INSERT WRENCH#
3/4" SQ	DAV-CIN-SCR	DAV-CIN-WR
1" SQ	DAV-CIN-SCR-ISO	DAV-CIN-WR

See Page 54 for inserts.

### NEW BRITAIN CUT-OFF TOOLHOLDERS

TOOLHOLDERS SHOWN USE .750 SQ INSERT

Patent No. D307859

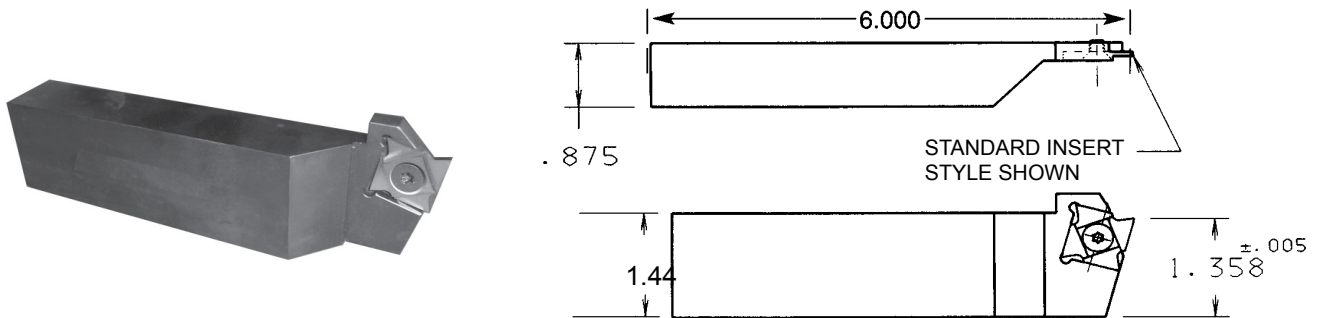

TOOLHOLDER CAT. #	INSERT SIZE	INSERT SCREW	INSERT WRENCH
NB-CIN	3/4"	DAV-CIN-SCR	DAV-CIN-WR
NB-CIN-EX	1"	DAV-CIN-SCR-ISO	DAV-CIN-WR

See Page 54 for inserts.