

### COUNTERSINK HOLDERS WITH MICRO-GRAIN CARBIDE AND T15PM INSERTS

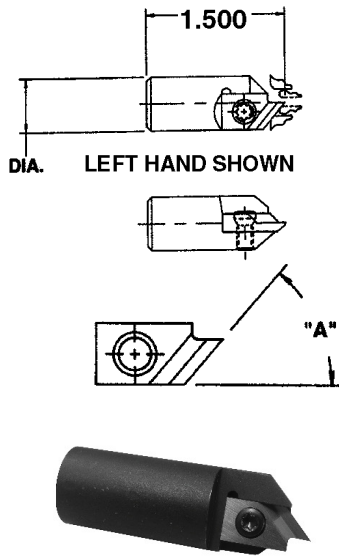

LEFT HAND

RIGHT HAND

SHANK DIA.	INCL'D. ANGLE	HOLDER CAT. NO.	CARBIDE INSERT CAT. NO.	"A"	T15PM INSERT CAT. NO.
3/8	82 DEG.	DAV-CSK-3/8	DAV-CSI-LH41	41 DEG.	DAV-CSI-LH41-P
3/8	90 DEG.	DAV-CSK-3/8	DAV-CSI-LH45	45 DEG.	DAV-CSI-LH45-P
3/8	100 DEG.	DAV-CSK-3/8	DAV-CSI-LH50	50 DEG.	DAV-CSI-LH50-P
3/8	120 DEG.	DAV-CSK-3/8-120	DAV-CSI-LH60	60 DEG.	DAV-CSI-LH60-P
10MM	90 DEG.	DAV-CSK-10MM	DAV-CSI-LH45	45 DEG.	DAV-CSI-LH45-P
7/16	90 DEG.	DAV-CSK-7/16	DAV-CSI-LH45	45 DEG.	DAV-CSI-LH45-P
1/2	82 DEG.	DAV-CSK-1/2	DAV-CSI-LH41	41 DEG.	DAV-CSI-LH41-P
1/2	90 DEG.	DAV-CSK-1/2	DAV-CSI-LH45	45 DEG.	DAV-CSI-LH45-P
1/2	100 DEG.	DAV-CSK-1/2	DAV-CSI-LH50	50 DEG.	DAV-CSI-LH50-P
1/2	120 DEG.	DAV-CSK-1/2-120	DAV-CSI-LH60	60 DEG.	DAV-CSI-LH60-P
5/8"	90 DEG.	DAV-CSK-5/8	DAV-CSI-LH45	45 DEG.	DAV-CSI-LH45-P
3/4"	90 DEG.	DAV-CSK-3/4	DAV-CSI-LH45	45 DEG.	DAV-CSI-LH450-P

SHANK DIA.	INCL'D. ANGLE	HOLDER CAT. NO.	CARBIDE INSERT CAT. NO.	"A"	T15PM INSERT CAT. NO.
3/8	82 DEG.	DAV-CSK-3/8-R	DAV-CSI-RH41	41 DEG.	DAV-CSI-RH41-P
3/8	90 DEG.	DAV-CSK-3/8-R	DAV-CSI-RH45	45 DEG.	DAV-CSI-RH45-P
3/8	100 DEG.	DAV-CSK-3/8-R	DAV-CSI-RH50	50 DEG.	DAV-CSI-RH50-P
3/8	120 DEG.	DAV-CSK-3/8-120-R	DAV-CSI-RH60	60 DEG.	DAV-CSI-RH60-P
10MM	90 DEG.	DAV-CSK-10MMR	DAV-CSI-RH45	45 DEG.	DAV-CSI-RH45-P
7/16	90 DEG.	DAV-CSK-7/16R	DAV-CSI-RH45	45 DEG.	DAV-CSI-RH45-P
1/2	82 DEG.	DAV-CSK-1/2-R	DAV-CSI-RH41	41 DEG.	DAV-CSI-RH41-P
1/2	90 DEG.	DAV-CSK-1/2-R	DAV-CSI-RH45	45 DEG.	DAV-CSI-RH45-P
1/2	100 DEG.	DAV-CSK-1/2-R	DAV-CSI-RH50	50 DEG.	DAV-CSI-RH50-P
1/2	120 DEG.	DAV-CSK-1/2-120-R	DAV-CSI-RH60	60 DEG.	DAV-CSI-RH60-P
5/8"	90 DEG.	DAV-CSK-5/8-R	DAV-CSI-RH45	45 DEG.	DAV-CSI-RH45-P
3/4"	90 DEG.	DAV-CSK-3/4-R	DAV-CSI-RH45	45 DEG.	DAV-CSI-RH45-P

- COUNTERSINK RANGE .035 TO .325 DIA.
- LARGER RANGES AVAILABLE
- R.H. AND L.H. STOCKED
- BACKWORKING LEFT HAND CUT
- USED TO CHAMFER BACKEND OF PART I.D.
- REPEATABILITY WITHIN .001
- MINIMUM DOWN TIME
- ALSO AVAILABLE IN 1", 2", AND 2-1/2" LENGTHS

USE T15PM INSERTS FOR SLOW SURFACE FEET PER MINUTE OR MACHINES THAT LACK RIGIDITY.

Also available tin coated - Add TIN to Insert Part #

#### HOLDER PARTS

CAT. NO.	ITEM
DAV-CSK-SCR	TORX SCREW
DAV-CSK-WR	TORX WRENCH

### SOLID MICRO-GRAIN CARBIDE COUNTERSINK TOOLS FOR DAVENPORT MACHINES

CAT. NO.	"A" DIA.
DAV-CSK-LH	3/8

- FOR LEFT HAND CUT

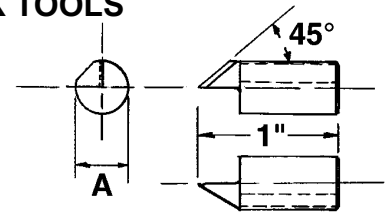

MINIATURE MULTI-FLUTE COUNTERSINKS 3/32" Shank dia - 1-5/8"		
HEAD DIA	FLUTE LENGTH	PART #
1/16"	.081"	LM2-062
3/32"	.122"	LM2-093
1/8"	.162"	LM2-125
3/16"	.244"	LM2-187
1/4"	.325"	LM2-250
5/16"	.407"	LM2-312

### Miniature Multi-Flute Countersinks 3/32" Shank Diameter - 1-5/8"

Used on small hole and parts to chamfer or break the edge. May be resharpened many times. 3/32" shanks 25° C/L angle.