

MAX-BAR 6mm 35° SERIES TOOLING



FULL RADIUS

(REG. U.S. PATENT)
 (NO. 5,779,400)
 (NO. 6,033,158)

WITH ONE TOOLHOLDER
 JUST CHANGE INSERT

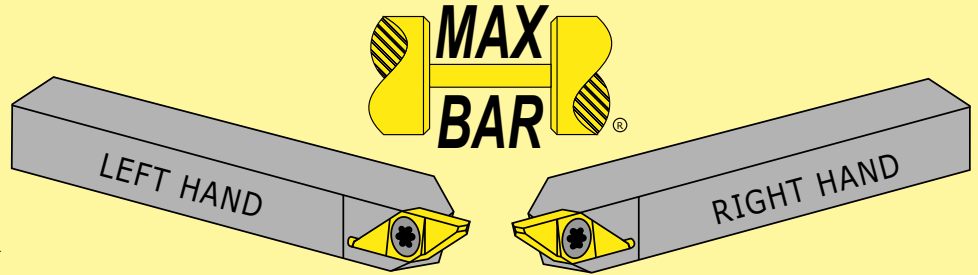

FULL RADIUS

RIGHT HAND SHOWN

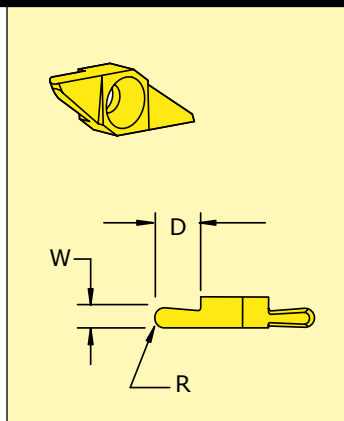

R.H. INSERT NO.	L.H. INSERT NO.	WIDTH		DEPTH		RADIUS	
		INCH	MM	INCH	MM	INCH	MM
VFRR-6M010	VFRL-6M010	.010	0,25	.030	0,76	.005	0,13
VFRR-6M015	VFRL-6M015	.015	0,38	.040	1,00	.007	0,19
VFRR-6M020	VFRL-6M020	.020	0,50	.050	1,30	.010	0,25
VFRR-6M025	VFRL-6M025	.025	0,63	.065	1,65	.012	0,32
VFRR-6M030	VFRL-6M030	.030	0,76	.090	2,30	.015	0,38
VFRR-6M040	VFRL-6M040	.040	1,00	.110	2,80	.020	0,50
VFRR-6M047	VFRL-6M047	.047	1,20	.130	3,30	.023	0,60
VFRR-6M062	VFRL-6M062	.062	1,57	.160	4,06	.031	0,78
VFRR-6M078	VFRL-6M078	.078	1,98	.180	4,57	.039	1,00
VFRR-6M093	VFRL-6M093	.093	2,36	.180	4,57	.046	1,20

TOOLHOLDERS

RIGHT HAND SHOWN

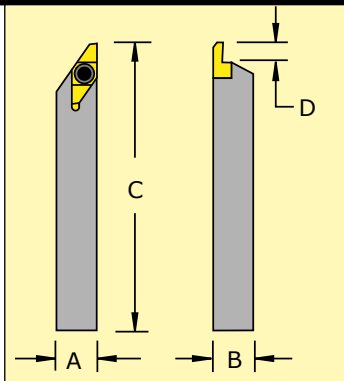

R.H. Holder No.	L.H. Holder No.	A	B	C	D
SVANR-07M6M-C	SVANL-07M6M-C	7mm	7mm	127mm	5mm
SVANR-08M6M-C	SVANL-08M6M-C	8mm	8mm	127mm	5mm
SVANR-10M6M-C	SVANL-10M6M-C	10mm	10mm	127mm	5mm
SVANR-12M6M-C	SVANL-12M6M-C	12mm	12mm	127mm	5mm
SVANR-3756M-C	SVANL-3756M-C	.375	.375	5.00	.200
SVANR-5006M-C	SVANL-5006M-C	.500	.500	5.00	.200
SVANR-6256M-C	SVANL-6256M-C	.625	.625	5.00	.200
SVANR-7506M-C	SVANL-7506M-C	.750	.750	5.00	.200
SPARE PARTS	SCREW 2.40-064	WRENCH T-7			

MAX-BAR 6mm 35° DIAMOND BARS

FOR TURRET & GANG LOADING/BACK WORKING

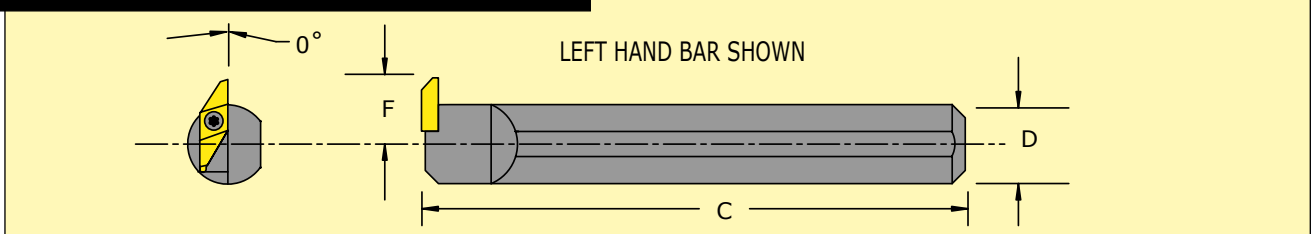

R.H. BAR NO.	L.H. BAR NO.	INSERT	D	C	F	SCREW	WRENCH
S10D-SVFNR6M	S10D-SVFNL6M	6MM-35	.625	5.75	.515	2.40-064	T-7
S12D-SVFNR6M	S12D-SVFNL6M	6MM-35	.750	5.75	.575	2.40-064	T-7

NOTE: RIGHT HAND BARS USE LEFT HAND INSERTS/LEFT HAND BARS USE RIGHT HAND INSERTS

MAX-BAR 50° SERIES TOOLING



FULL RADIUS

RIGHT HAND SHOWN

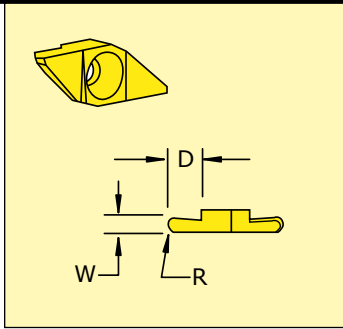

R.H. INSERT NO.	L.H. INSERT NO.	WIDTH		DEPTH		RADIUS	
		INCH	MM	INCH	MM	INCH	MM
KFRR-4125	KFRL-4125	.125	3,18	.300	7,62	.062	1,58
KFRR-4093	KFRL-4093	.093	2,36	.300	7,62	.047	1,19
KFRR-4078	KFRL-4078	.078	1,98	.300	7,62	.039	1,00
KFRR-4062	KFRL-4062	.062	1,57	.250	4,83	.031	0,78
KFRR-4047	KFRL-4047	.047	1,19	.190	4,83	.023	0,60
KFRR-4031	KFRL-4031	.031	0,79	.080	2,03	.015	0,40

TOOLHOLDERS

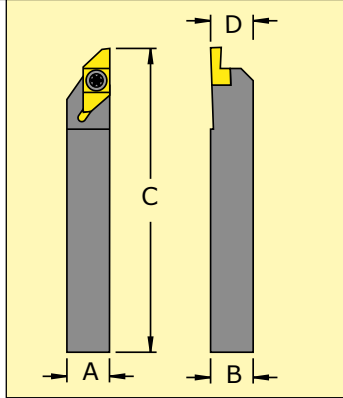

R.H. HOLDER NO.	L.H. HOLDER NO.	A	B	C	D
SKANR-104-V	SKANL-104-V	.625	.625	3.50	.630
SKANR-104-C	SKANL-104-C	.625	.625	5.00	.630
SKANR-124-V	SKANL-124-V	.750	.750	3.50	.755
SKANR-124-C	SKANL-124-C	.750	.750	5.00	.755
SKANR-164-C	SKANL-164-C	1.00	1.00	5.00	1.00
SPARE PARTS	SCREW 4.76-127	WRENCH T-25			

MAX-BAR RIGHT ANGLE HOLDERS

FOR TURRET & GANG LOADING

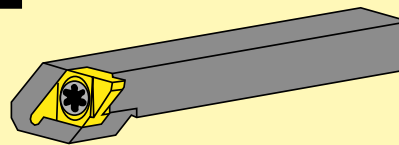
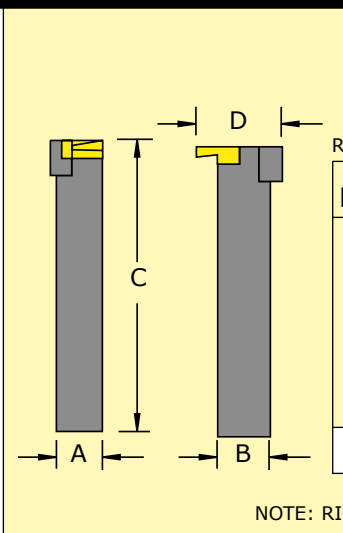

RIGHT HAND SHOWN

R.H. HOLDER NO.	L.H. HOLDER NO.	A	B	C	D	SCREW	WRENCH
SKFNR-064-D	SKFNL-064-D	.375	.500	4.50	1.15	4.76-127	T-25
SKFNR-084-D	SKFNL-084-D	.500	.500	4.50	1.15	4.76-127	T-25
SKFNR-104-D	SKFNL-104-D	.625	.625	4.50	1.15	4.76-127	T-25
SKFNR-124-D	SKFNL-124-D	.750	.750	5.00	1.05	4.76-127	T-25
SKFNR-164-D	SKFNL-164-D	1.00	1.00	5.00	1.30	4.76-127	T-25

NON-STANDARD SHANK SIZES AND RECTANGULAR SHANKS AVAILABLE ON REQUEST

NOTE: RIGHT HAND HOLDERS USE LEFT HAND INSERTS. LEFT HAND HOLDERS USE RIGHT HAND INSERTS.